

PARTS DEFINITIONS

Bicycle carrier skewer: brass rod running through the inside of the skewer housing

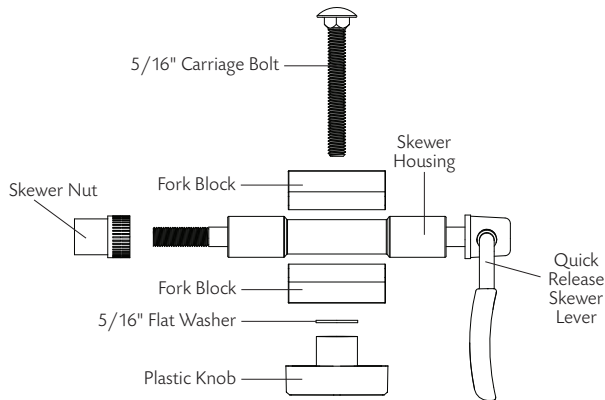

NOTE: The 080-BC-10 Bicycle Carrier may only be used on load bar model SL-13. Use of carrier on other load bars could result in damage to your bicycle forks.

INSTALLING THE BICYCLE CARRIER

The bicycle carrier may be installed on the main tube of the cargo bracing bar or the extension tube of the cargo bracing bar.

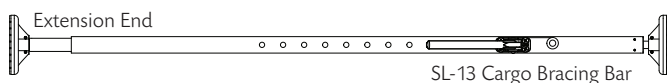

1. Separate the clamp's fork blocks by turning the bicycle carrier's plastic knob counter-clockwise.
2. Clamp the fork blocks around the bracing bar:
 - a) If installing the carrier on the main tube, clamp the two fork blocks around the cargo bar and the bicycle carrier skewer housing.
 - b) If installing the carrier on the extension tube, insert the clamp adapter between a fork block and the cargo bar with the U-shaped slot around the carriage bolt.



3. Tighten the plastic knob (clockwise) at the desired position on the cargo bar.

NOTE: The bicycle carrier skewer rod should move freely in the skewer housing. The skewer should move when the skewer lever or skewer nut is pushed. Do not use the skewer if it is bent or it does not move freely.

If the skewer is too tight in the housing:

1. Remove the skewer nut and remove the skewer from the housing.
2. Apply a small amount of multipurpose grease to the skewer and re-assemble.

ATTACHING THE BICYCLE

1. Remove the front wheel of the bicycle.
2. Move the skewer lever into the open position.
3. Set the bicycle forks onto the skewer.

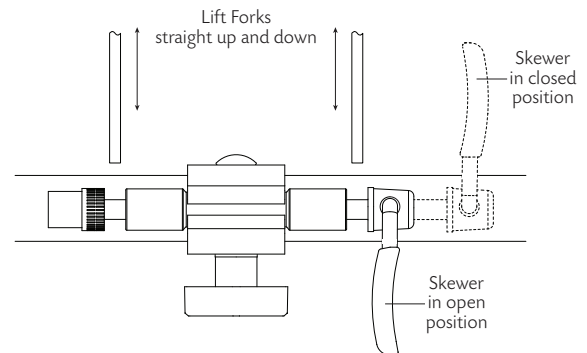

NOTE: The front fork dropouts should be completely on the skewer.

4. Hand tighten the skewer nut against the bicycle fork. Do not over tighten.
5. Close the skewer by flipping the lever 180 degrees.

NOTE: Resistance should be felt when closing the lever. Loosen or tighten the skewer nut to adjust the amount of pressure required to close the lever. Do not over tighten the lever. The bicycle forks should fit snugly on the skewer and the pressure required to close the skewer should leave an impression on the palm of your hand.