



TOOLS NEEDED

- Philips Screwdriver
- Drill and 1-1/8" Drill Bit

COMPONENTS

- 1 – Locking Sleeve 080-LS-10P
- 1 – Sheet Metal Screw

ASSEMBLING LOCKING SLEEVE TO SL-10 SERIES LOAD BAR

1. Remove extension tube from the main tube.

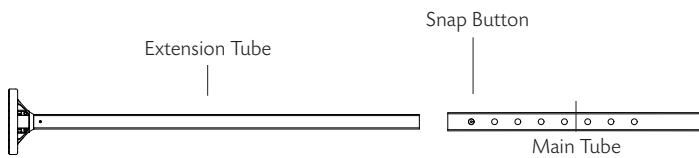

2. Remove the handle bracket assembly by unscrewing the four screws from the handle bracket and lift off.

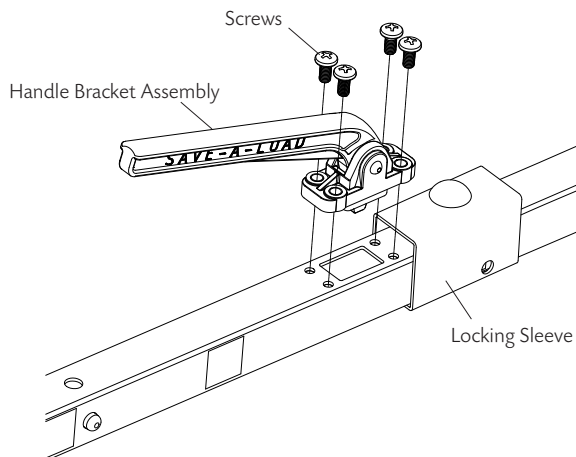

3. Slide the locking sleeve on the main tube from the extension tube end and over the red release button. Ensure offset on sleeve matches offset of release button.

4. Reinstall the handle bracket assembly.

5. Drill 1/4" deep hole in location shown below. Make sure it is located no more than 3/4" from the end of the bar, on aluminum only and avoiding the roll pin area.

6. Insert Srew. Do not overtighten.

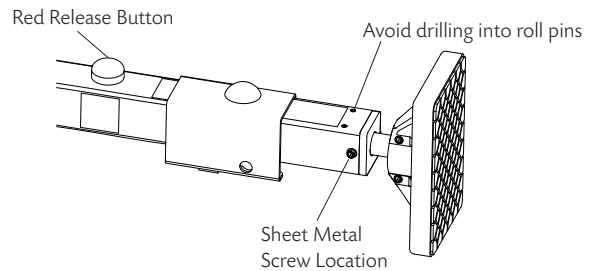

IMPORTANT:

Inserting the screw anywhere but the location noted in step five could risk damage to the internal hydraulic pump.

To secure your load bar, simply slide the locking sleeve collar over the release button and secure with padlock (not provided).